

Impedance Analyzer IM3570 option

Enabling Simple Circuit Analysis and Detailed Acceptance/Rejection Decision-Making

The Equivalent Circuit Analysis Firmware IM9000 is an optional function that enables equivalent circuit analysis using the Impedance Analyzer IM3570. Five typical equivalent circuit analysis models and the analysis results can be used to calculate the ideal frequency characteristics and check the differences from the measured values. Furthermore, Cole-Cole plot, admittance circle, and other graphs can be displayed.

Impedance Analyzer IM3570



■ *The Equivalent Circuit Analysis Firmware IM9000 Provides an Optional Function to Perform a Variety of Equivalent Circuit Analysis and Display Graphs.*

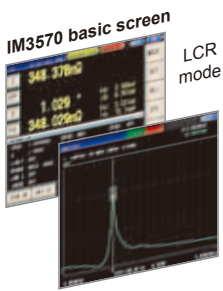

Frequency sweep mode

IM9000 optional function screen

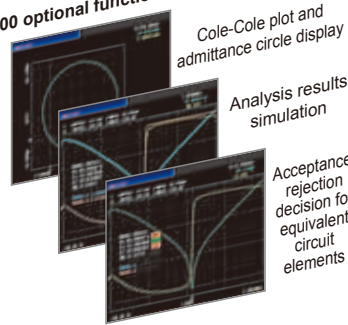

- **Five equivalent circuit analysis (Auto/Fixed) patterns**
- **Acceptance/rejection decision for equivalent circuit elements**
- **Analysis results simulation**
- **Cole-Cole plot and admittance circle display**

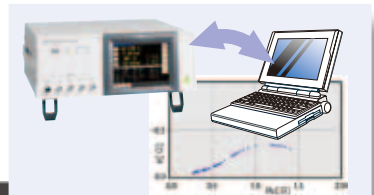
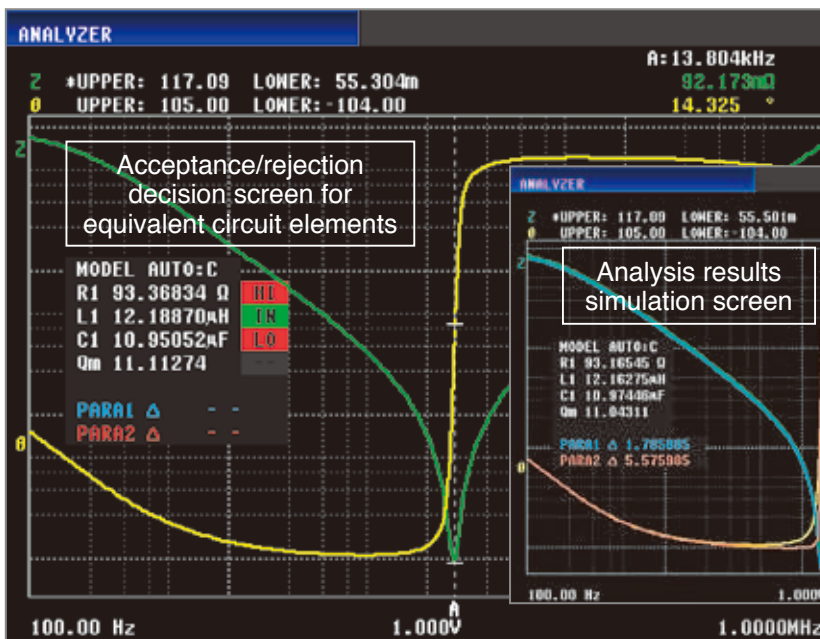

Cole-Cole plot and admittance circle graphs that previously needed a PC to be displayed can now be shown on the IM3570 screen.

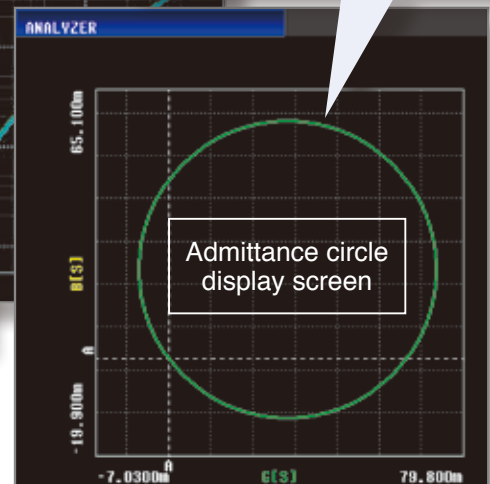
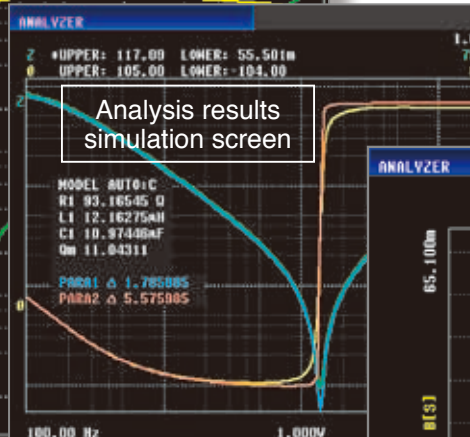

■ Features

● Simple: Automatic Selection of Equivalent Circuit Model

The IM9000 can automatically select the equivalent circuit model from the five typical models to minimize the differences between the measured values and the ideal frequency characteristics derived from the analysis results.

● Detailed: Acceptance/Rejection Decision for Elements Comprising Part

An acceptance/rejection decision can be made for the L, C, and R elements comprising a part and the resonance sharpness (mechanical quality coefficient). A detailed decision can be made on the elements using the resonance of a piezoelectric element or inductor.

■ Equivalent Circuit Analysis Firmware IM9000 Specifications

● Equivalent Circuit Model and Measurement Items

■ Three-element model

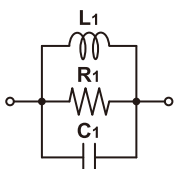
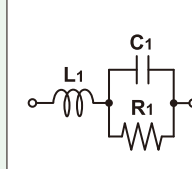
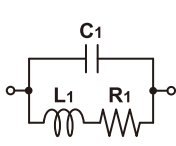
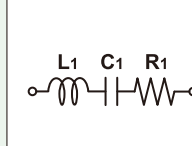
A		Coil: Core loss is large while ESR is small	C		Capacitor: Impact of the leakage resistance is large Resistance: Resistance is large and impact of the floating capacitance is large
B		Coil: ESR is relatively large Resistance: Resistance is small and impact of the wire inductance is large	D		Capacitor: General capacitor

■ Measurement items (Three-element model)

L1 (Inductance)
C1 (Capacitance)
R1 (Resistance)
Qm (Resonance sharpness)
fr (Resonance frequency) /
fa (Anti-resonance frequency)

■ Four-element model

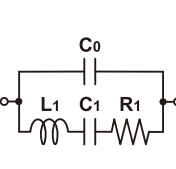
E		Piezoelectric element
---	--	-----------------------

■ Measurement items (Four-element model)

L1 (Inductance)
C1 (Capacitance)
R1 (Resistance)
C0 (Parallel capacitance)
Qm (Resonance sharpness or mechanical quality coefficient)
fr (Resonance frequency)
fa (Anti-resonance frequency)
fs (Series resonance frequency)
fp (Parallel resonance frequency)
fm (Maximum admittance frequency)
fn (Minimum admittance frequency)
f1 (Maximum susceptance frequency)
f2 (Minimum susceptance frequency)

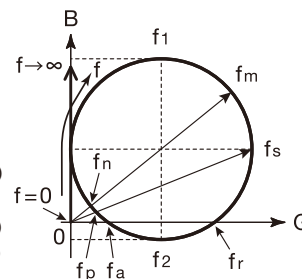

Parameters of the 4-element model

● Other functions

Circuit model selection	AUTO (automatic selection) / HOLD (fixed)
Estimation execution	AUTO (estimation is executed after frequency sweep ends) / MANUAL (estimation is executed by the user)
Sweep range using estimation	Normal sweep: Analysis is performed in the sweep range from the analysis start frequency to the analysis end frequency Segment sweep: Analysis is performed in the sweep range of the set segment number
Simulation	Enables displaying and comparing the ideal frequency characteristics graph derived from the analysis results or the values specified by the user

Comparator	Runs a comparator on the analysis results and outputs the decision results to LCD, EXT. I/O R1, L1, C1, C0, Qm: HI/IN/LO, absolute value setting
Display position of estimation results	Select the display position from upper, lower, left or right
X-Y display	Cole-Cole plot: Set Rs to the first measurement item, X to the third measurement item, reverse the polarity of the third measurement item, and set correction coefficient A = -1 for scaling correction Admittance circle display: Set G to the first measurement item and B to the third measurement item

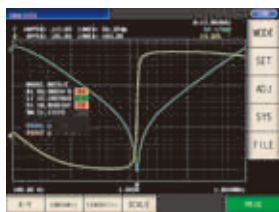

Model : EQUIVALENT CIRCUIT ANALYSIS FIRMWARE IM9000

Model No. (Order Code) (Note)

IM9000 (Factory option firmware for the IM3570)

The Equivalent Circuit Analysis Firmware IM9000 is an optional function for the Impedance Analyzer IM3570. The IM9000 is not included in the standard package. If you want to use the IM9000 function, specify the option upon purchase.

Customers who have purchased the Impedance Analyzer IM3570 can add the Equivalent Circuit Analysis Firmware IM9000 function. Please contact your local HIOKI representative.

Note: Company names and Product names appearing in this catalog are trademarks or registered trademarks of various companies.

HIOKI

HIOKI E. E. CORPORATION

HEADQUARTERS

81 Koizumi, Ueda, Nagano, 386-1192, Japan
TEL +81-268-28-0562 FAX +81-268-28-0568
http://www.hioki.com / E-mail: os-com@hioki.co.jp

HIOKI USA CORPORATION

TEL +1-609-409-9109 FAX +1-609-409-9108
http://www.hiokiusa.com / E-mail: hioki@hiokiusa.com

HIOKI (Shanghai) SALES & TRADING CO., LTD.
TEL +86-21-63910090 FAX +86-21-63910360
http://www.hioki.cn / E-mail: info@hioki.com.cn

DISTRIBUTED BY

HIOKI SINGAPORE PTE. LTD.
TEL +65-6634-7677 FAX +65-6634-7477
E-mail: info-sg@hioki.com.sg

HIOKI KOREA CO., LTD.
TEL +82-2-2183-8847 FAX +82-2-2183-3360
E-mail: info-kr@hioki.co.jp